

CONTAINERS

Hook Containers

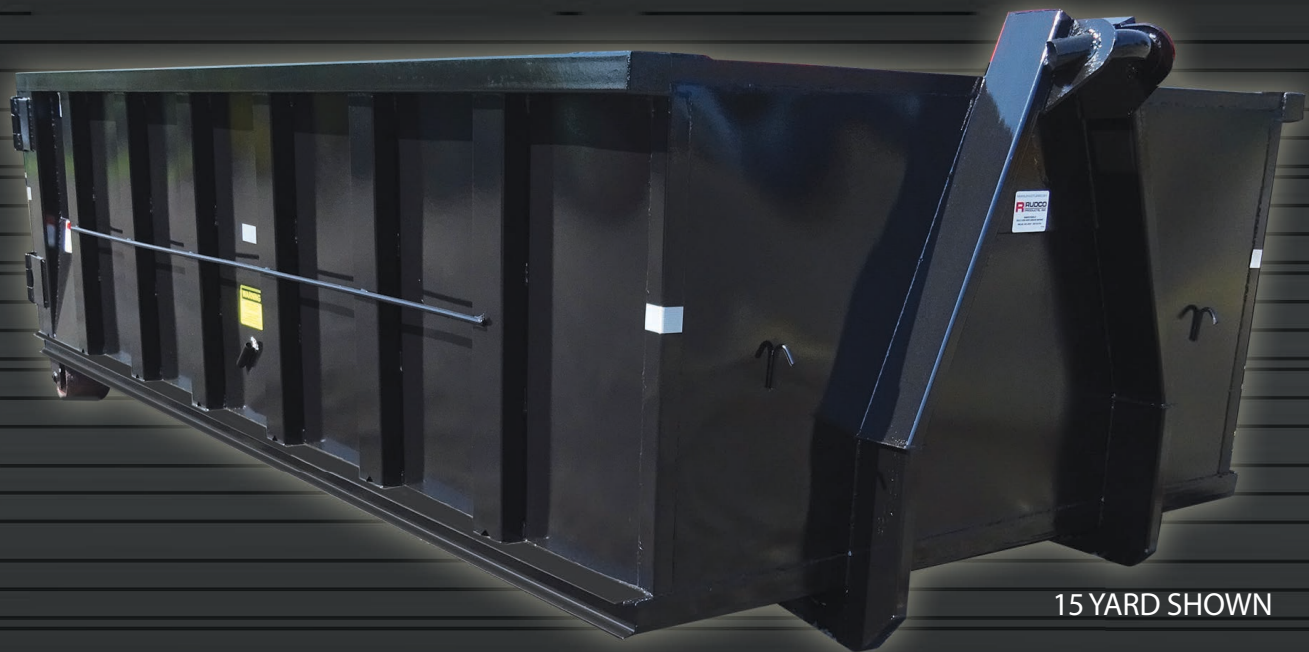

15 YARD SHOWN

FEATURING:

- Tube main rails and tube bullnose which ties into front hook system
- All containers are primed and painted in one of 10 standard colors
- Non-Sagging Tailgate is designed to rest on floor of container
- Tubing Headers on all sides
- Optional: Containers Stops can be added to accommodate all hook systems (must specify make and model)
- Notches in each of the Vertical Support Columns prevent moisture retention
- Minor changes can be made to fit standard understructure

ALL PRODUCTS ARE BUILT RUDCO TOUGH IN THE USA



Rental Program And Financing Available

Toll Free: 1.800.828.2234 • E-Mail: sales@rudco.com

www.rudco.com

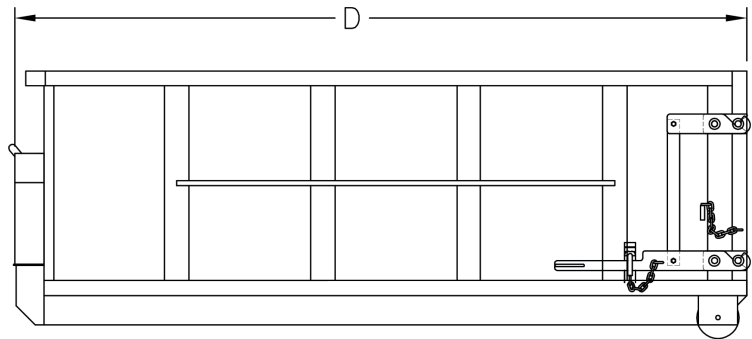
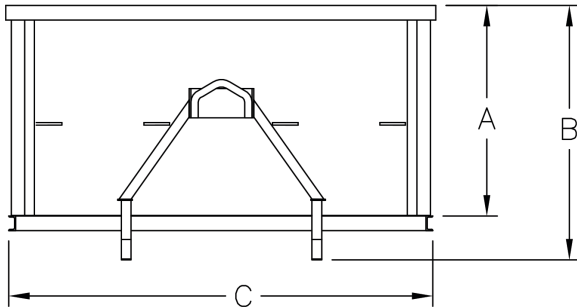

SIZE	(A) HEIGHT INSIDE	(B) HEIGHT OUTSIDE	(C) WIDTH OVERALL	(D) LENGTH OVERALL	APPROX. WEIGHT
10 YD	43"	52"	96"	12' 7"	2,437 LBS.
15 YD	62"	71"	96"	12' 7"	2,843 LBS.
13 YD	43"	52"	96"	14' 7"	2,630 LBS.
19 YD	62"	71"	96"	14' 7"	3,316 LBS.
16 YD	43"	52"	96"	16' 7"	2,835 LBS.
23 YD	62"	71"	96"	16' 7"	3,790 LBS.

STANDARD DECK

- 3/16" Plate Floor Sheet
- 3" Structural Channel on 20" Centers
- 3/16" PL. Gussets on every other Cross Member
- 6" x 2" x 3/16" Tube One Piece Main Rail
- Two 8" diameter x 5" LG. Heavy Duty Wheels
- Two Diagonal 6" x 2" x 3/16" Tube for Front Hook Assembly Supports w/1 1/2" RB Hook and Formed 3/8" Hook Mount/Crash Plate

FRONT and SIDES

- 11 Ga. Sheet with Tie Down Bars on both Sides and Four Tie Down Hooks on Front
- 4" x 3" x 11 Ga. Top Tube
- 11 Ga. 3" x 5" Formed 4-way Bend Side and Front Stiffener Columns on 20" Centers. Stiffener Columns have notches at bottom to prevent moisture retention
- 2"x2" Formed Corner wraps around front for extra strength and stability

REAR CORNER POST

- Latch Side 4" x 3" x 11 Ga. Tube
- Hinge Side 3" x 6-1/2" x 3/16" Formed Stiffener 4-way Bend

REAR DOOR

- 11 Ga. Sheet w/4" x 3" x 11 Ga. Tube Frame and 3/8" Safety Chain
- Hinges 1/2" x 7" x 9" and 1/2" x 3" x 4" Plates with 2" OD Mechanical Tube Bushings with Grease Fittings and 1-3/16" Cold Rolled Pin
- Non-Sagging Door is designed to rest on the floor of the container
- Tie Down Hooks 1/2"

DOOR LOCK

- Southern Style Latch - Hook & Pin Style
- Upgrade Option: Vertical Lift Handle System. Semi-automatic Cam Locking System with cams and Self-Aligning Keeper. The Vertical Lift Handle is securely welded to a cam style for easy opening and closing operation. Handle is secured by a 3/4" solid pin, 180° turn keyway locking system.



NOTE: OPEN TOP CONTAINERS can be stacked 5 or 6 per load. This saves freight cost per container. However, when stacking and unstacking, doors have to be removed and re-hung, and the containers may be scratched or dented. We cannot be responsible for this happening since it is unavoidable when stacking containers.

RUDCO RESERVES THE RIGHT TO REVISE, AMEND AND IMPROVE IT'S EQUIPMENT WITHOUT NOTICE

CORPORATE OFFICE: 114 E. Oak Rd. • Vineland, NJ 08360 • Ph: 1.856.691.0800 • Fax: 1.856.696.008

MAILING ADDRESS: P.O. Box 705 • Vineland, NJ 08362

Toll Free: 1.800.828.2234 • E-Mail: sales@rudco.com
Phone: 1.856.691.0800 • Fax: 1.856.696.8654

rudco.com