

HOISTS

Roll-Off Hoist (Inside-Outside Rail or Outside Rail)

50,60 and 75,000 LB.
Capacity Models Available



FEATURING:

- 52° Dump Angle
- Single Stage Interchangeable Cylinders for both Lift and Reeving Cylinders
- 4" x 3" x 1/4" Sub Frame
- 1/4" Wear Strips (Outside Rail Only) (60,000 & 75,000 lb. Models)
- Rear Cable Storage Hook
- Safety Props Both Sides
- 1/2" Bracket wrapped around roller pins
- Back-Up Alarm (Self-Adjusting Volume)
- Folding Bumper With Lock Pins
- Certified Rear Hold Downs as required by law

OPTIONS

- Air Shift P.T.O.
- Full Fenders
- Tool Box
- Inside Controls
- ADDITIONAL OPTIONS AVAILABLE

ALL PRODUCTS ARE BUILT RUDCO TOUGH IN THE USA

R | **RUDCO**
PRODUCTS, INC



Rental Program And Financing Available

Toll Free: 1.800.828.2234 • E-Mail: sales@rudco.com

www.rudco.com

HOISTS

Roll-Off Hoist

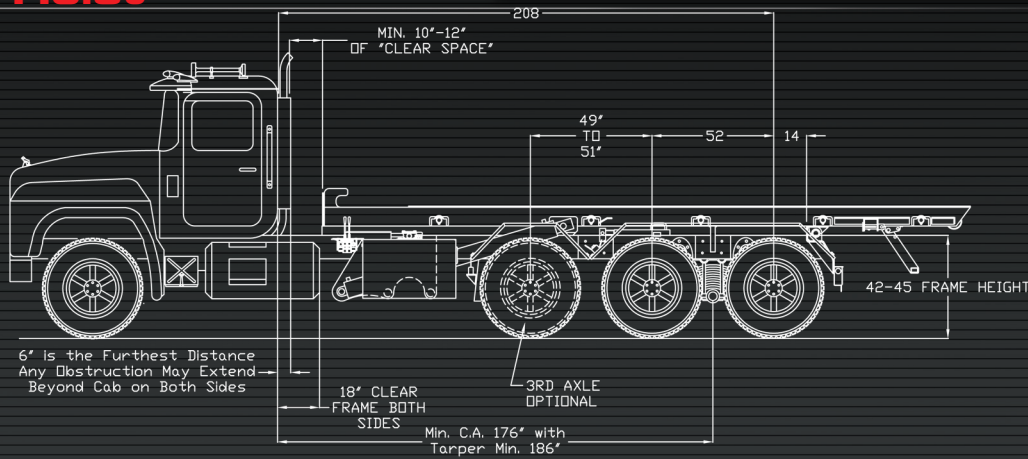

Roll-Off Hoist Specifications

RATED CAPACITY	50,000 LBS.	60,000 LBS.	60,000 LBS.	60,000 LBS.	75,000 LBS.	75,000 LBS.	75,000 LBS.	75,000 LBS.
LIFT CYLINDERS (BORE X STROKE X ROD)	6" X 80" X 4-3/4" D.A.	6" X 80" X 4-3/4" D.A.	6", 5", 4" X 120" D.A.T. TELESCOPIC	6" X 81" X 4-3/4"	7" X 81" X 4-3/4" D.A.	6", 5", 4" X 120" D.A.T. TELESCOPIC	7" X 81" X 4-3/4" D.A.	7" X 81" X 4-3/4" D.A.
REEVING CYLINDERS (BORE X STROKE)	6" X 81" X 4-3/4" D.A.	6" X 81" X 4-3/4" D.A.	6" X 81" X 4-3/4" D.A.	6" X 81" X 4-3/4" D.A.	7" X 81" X 4-3/4" D.A.	7" X 81" X 4-3/4" D.A.	7" X 81" X 4-3/4" D.A.	7" X 81" X 4-3/4" D.A.
TAIL CYLINDERS (BORE X STROKE X ROD)	3-1/2" X 80" X 2-1/2" D.A.	N/A	N/A	N/A	N/A	N/A	N/A	N/A
CABLE	7/8" X 75.9" (6X25 IWRC,EIPS 79,600 LBS.)	7/8" X 75.9" (6X25 IWRC,EIPS 79,600 LBS.)	7/8" X 75.9" (6X25 IWRC,EIPS 79,600 LBS.)	7/8" X 75.9" (6X25 IWRC,EIPS 79,600 LBS.)	7/8" X 75.9" (6X25 IWRC,EIPS 79,600 LBS.)	7/8" X 75.9" (6X25 IWRC,EIPS 79,600 LBS.)	7/8" X 75.9" (6X25 IWRC,EIPS 79,600 LBS.)	7/8" X 75.9" (6X25 IWRC,EIPS 79,600 LBS.)
HOIST LENGTH	238" - 318"	276"	286"	276"	276"	286"	276"	276"
CONTAINER LENGTH	12' - 22'	12' - 24'	12' - 22'	12' - 22'	12' - 22'	12' - 24'	12' - 24'	12' - 22'
OPERATING PRESSURE	2150	2150	2150	2150	2150	2150	2150	2150
HOIST UP	25	26	29	26	26	28	26	26
HOIST DOWN	13	17	17	17	21	23	21	21
WINCH ON	27	26	29	26	26	28	26	26
WINCH OFF	20	17	17	17	21	23	21	21
SUB-FRAME	4" X 3" X 1/4" TUBE	4" X 3" X 1/4" TUBE	4" X 3" X 1/4" TUBE	4" X 3" X 1/4" TUBE	4" X 3" X 1/4" TUBE	4" X 3" X 1/4" TUBE	4" X 3" X 1/4" TUBE	OPTIONAL
TOP RAIL DIVIDER BAR	N/A	NA	N/A	3/4" x 2-1/2" ALLOY STEEL	N/A	N/A	3/4" x 2-1/2" ALLOY STEEL	N/A
WEIGHT (WITH OIL AND MOUNTED)	9,400	8,000	8,150	8,140	8,140	8,290	8,280	8,475

- Single Stage Cylinders minimize problems. Rated at 3,000 PSI
- Rollers have outside Bracket for 3 Point Shaft Support
- All Roller (10) have Bronze Bushings and Grease Fittings
- 1/2" Steel Plate - Rear hinge and Cylinder Mounting Plates
- 2-1/2" Rear hinge Pin With 1-1/4" Support Plates
- Main Tube Frame is 1/2" wall x 8" x 4"
- ASTM A500-Grade. C-50,000# Yield Minimum
- Cable Sheaves are 10" Diameter W/ Alum-Bronze Bushing
- Unit Factory Tested at 60,000 lbs
- 52° Dump Angle on all Hoists
- High Tensile - full length Dividing Bar (Inside/Outside Only)
- Positive Container Lock for both Inside and Outside Rail Containers
- Heavy Duty Bumper - meets DOT Requirements
- Integral Rear Sealed Lights
- Cast Alloy Steel Universal Cable Hook Standard
- Rear Angle Guide
- Two Ratchet Strap Hold Downs

01/09 #109



CORPORATE OFFICE: 114 E. Oak Rd. • Vineland, NJ 08360 • Ph: 1.856.691.0800 • Fax: 1.856.696.0084
MAILING ADDRESS: P.O. Box 705 • Vineland, NJ 08362

Toll Free: 1.800.828.2234 • **E-Mail:** sales@rudco.com

www.rudco.com