

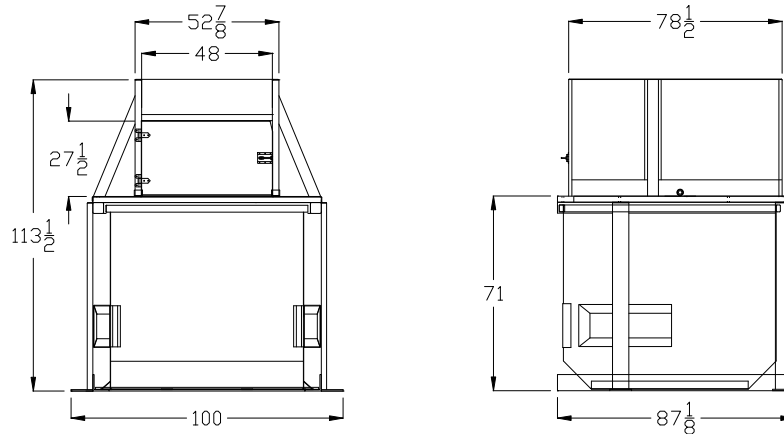

Vertical Compactor – 8 Cubic Yards Model RVP-8



CHARGE BOX CAPACITY AND DIMENSIONS

8 Cubic Yard Capacity
 Manufacturers Rating: .68 CU. YD.
 Hopper Width: 48"
 Hopper Depth: 37"
 Unit Weight 4,750#

Feed Height 71"
 Wastec Rating: .68 CU. YD.
 Hopper Height: 27 1/2"
 Ram Penetration: 17"
 Container Only Weight 1,350#

RAM DETAILS

3/16" Ram Face Plate w/ 5" x 3" x 1/2" Angle
 3/16" Ram Sides

Ram Face 1767sq in
 1 1/4" with Greaseable Pivot Shaft

PACKER FABRICATION DETAILS

10ga Housing Bottom
 6" x 2" x 3/16" Breaker Bar
 6" x 2" x 3/16" Support Legs

11ga Housing Side w/ 6" x 2" x 3/16" Side Stiffener
 6" Rear Mount Beam
 4" Angle Container Guides w/ Lock

INTERNAL POWER UNIT - ELECTRICAL AND HYDRAULIC DETAILS

3 HP Motor TEFC 208/230/460, 3 Phase
 4.3 GPM Pump Capacity
 Single Cylinder System
 Normal Pressure: 2,250
 Normal Ram Force: 28,260
 Normal Ram Force PSI: 16.0
 Cycle Time In Seconds: 20

NEMA 12 Control Panel, UL Rated
 7 Gallon Hydraulic Oil Tank w/ Site Gauge
 4" Bore x 2" Rod @ 16" Stroke
 Maximum Pressure: 2,500
 Maximum Ram Force: 31,400
 Maximum Ram Force PSI: 17.77
 Cubic Yards Per Hour: 76

OPERATION DETAILS

Push Button Starter, Automatic Cycle
 Turn Key Switch on 15' Cord
 Ram Retracts, Extends, Retracts And Stops Automatically

100% Full Light
 Drivers Light Removable for Multi Positions
 Door w/Safety Interlock

OPTIONAL EQUIPMENT

Single Phase, 3 HP, 220 Volt, 2.5 GPM Pump
 5 HP Motor TEFC 208/230/460, 3 Phase
 Oil Heater
 Steel Platform

Chute Kit
 Deodorizer/Spray can on Timer
 Pressure Gauge mounted by Door
 80% Full Light