

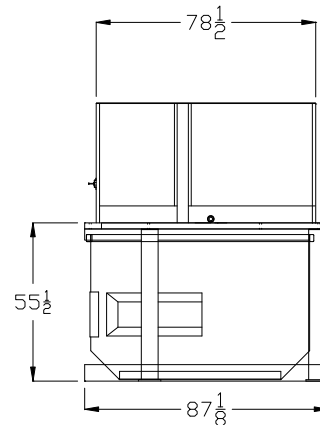

## Vertical Compactor – 6 Cubic Yards Model RVP-6

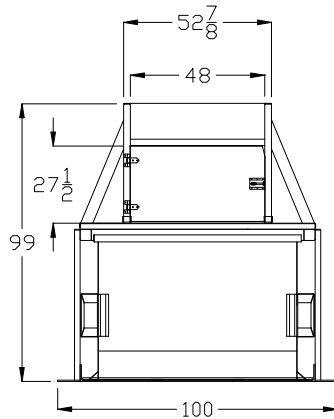

### CHARGE BOX CAPACITY AND DIMENSIONS

6 Cubic Yard Capacity  
 Manufacturers Rating: .68 CU. YD.  
 Hopper Width: 48"  
 Hopper Depth: 37"  
 Unit Weight 4,500#

Feed Height 55 1/2"  
 Wastec Rating: .68 CU. YD.  
 Hopper Height: 27 1/2"  
 Ram Penetration: 17"  
 Container Only Weight 1,100#

### RAM DETAILS

3/16" Ram Face Plate w/ 5" x 3" x 1/2" Angle  
 3/16" Ram Sides

Ram Face 1767sq in  
 1 1/4" with Greaseable Pivot Shaft

### PACKER FABRICATION DETAILS

10ga Housing Bottom  
 6" x 2" x 3/16" Breaker Bar  
 6" x 2" x 3/16" Support Legs

11ga Housing Side w/ 6" x 2" x 3/16" Side Stiffener  
 6" Rear Mount Beam  
 4" Angle Container Guides w/ Lock

### INTERNAL POWER UNIT - ELECTRICAL AND HYDRAULIC DETAILS

3 HP Motor TEFC 208/230/460, 3 Phase  
 4.3 GPM Pump Capacity  
 Single Cylinder System  
 Normal Pressure: 2,250  
 Normal Ram Force: 28,260  
 Normal Ram Force PSI: 16.0  
 Cycle Time In Seconds: 20

NEMA 12 Control Panel, UL Rated  
 7 Gallon Hydraulic Oil Tank w/ Site Gauge  
 4" Bore x 2" Rod @ 16" Stroke  
 Maximum Pressure: 2,500  
 Maximum Ram Force: 31,400  
 Maximum Ram Force PSI: 17.77  
 Cubic Yards Per Hour: 76

### OPERATION DETAILS

Push Button Starter, Automatic Cycle  
 Turn Key Switch on 15' Cord  
 Ram Retracts, Extends, Retracts And Stops Automatically

100% Full Light  
 Drivers Light Removable for Multi Positions  
 Door w/Safety Interlock

### OPTIONAL EQUIPMENT

Single Phase, 3 HP, 220 Volt, 2.5 GPM Pump  
 5 HP Motor TEFC 208/230/460, 3 Phase  
 Oil Heater  
 Steel Platform

Chute Kit  
 Deodorizer/Spray can on Timer  
 Pressure Gauge mounted by Door  
 80% Full Light